

Light Is On When Power Is Out

A loss of AC power during darkness (sensed by a photoresistor) turns on an array of battery-powered white LEDs. To conserve power, a timer turns off the LEDs after a particular period of time (for example, 10 minutes).

Power outages can occur when least expected, leaving you in total darkness. Whether in a hospital, a theater, or your home, such occasions call for an emergency lighting system that turns on automatically with loss of power. The preferred emergency light source is the white LED, which is gaining popularity as a compact, power-efficient alternative to the incandescent light bulb (**Figure 1**).

(Note: Use safety precautions when working with the high-voltage AC line.)

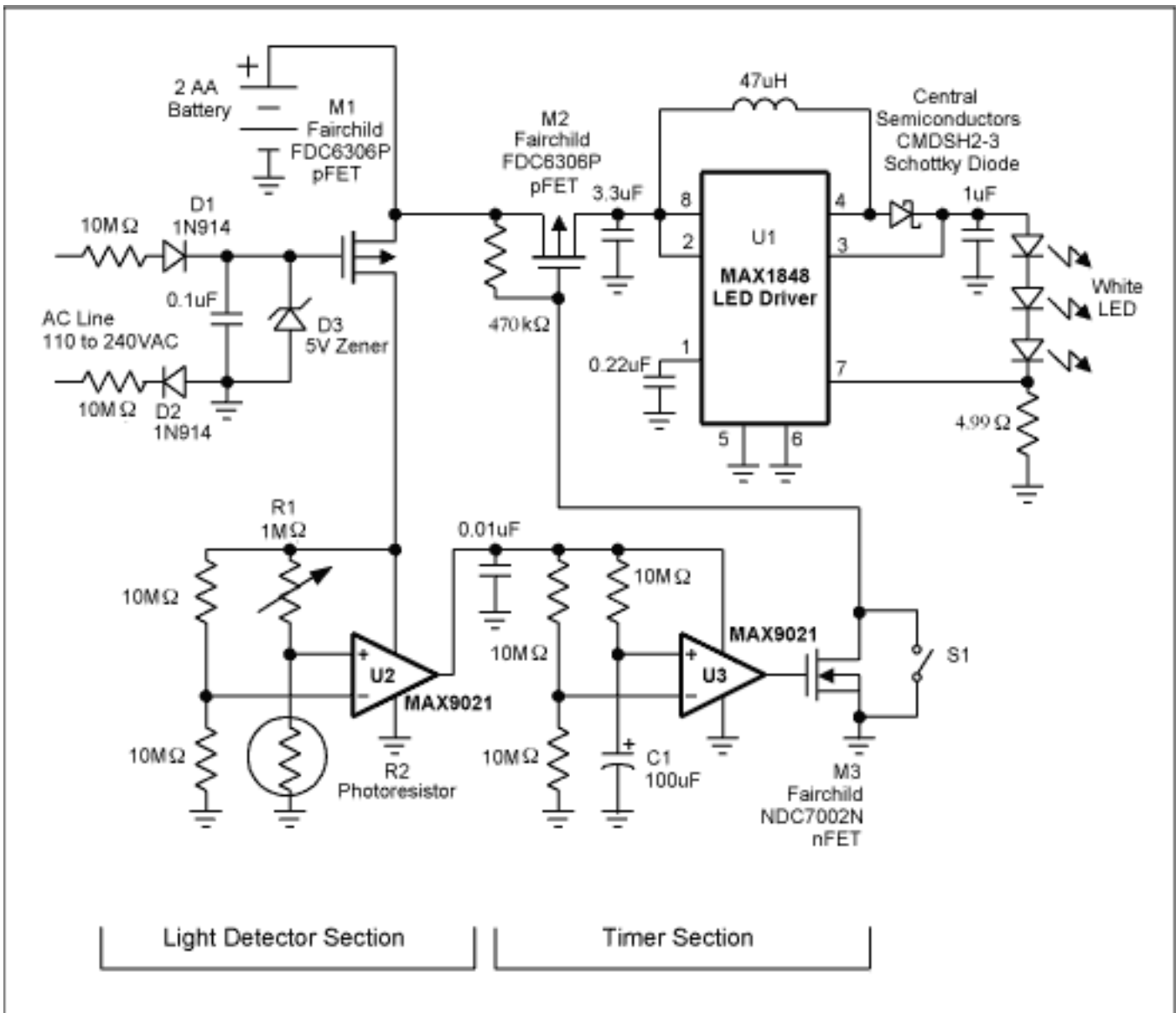

Figure 1. When AC power is lost, this emergency-lighting system automatically provides 10 minutes of illumination from a string of white LEDs.

The AC line voltage is rectified by D1 and D2, and D3 limits the resulting DC voltage to about 5V. When AC power is lost, the M1 gate voltage (normally 5V) goes to zero and turns on M1, which routes power from the battery to the light-detector section.

R2 is a cadmium-sulfide photoresistor the resistance of which changes from kilohms to megohms when the light intensity changes from daylight to darkness. R1 adjusts the light-level threshold. During darkness, the U2 output is logic high, which powers the timer section based on U3. U3 turns on M2 and M3, which turns on U1 and the LEDs. At the same time, C1 is charging. When its voltage reaches $V_{CC}/2$, the timer expires and shuts off M2, thereby saving battery energy by turning off the LEDs. For $C1 = 100\mu\text{F}$, the LEDs remain on for approximately 10 minutes following a power failure during darkness. (Closing S1 turns on the LEDs regardless of the timer interval.)

Leakage current from the battery is about 1 μ A when power is available. The capacity of a typical AA-size battery is about 2000mA-hours, so the standby time at 1 μ A is more than 200 years. During a power outage after the timer has expired, standby current for the R1-R2 values shown is about 7 μ A. Even at that rate, the standby life is about three times the 10-year shelf life of a typical battery. Current draw from the AC line is about 6 μ A, or less than 1mW at 120VAC, and current draw from the battery (with LEDs on) is about 100mA.

This design idea appeared in the October 4, 2004 issue of *Electronic Design* magazine.

More Information

MAX1848: [QuickView](#) -- [Full \(PDF\) Data Sheet](#) -- [Free Samples](#)

MAX9021: [QuickView](#) -- [Full \(PDF\) Data Sheet](#) -- [Free Samples](#)